

ONE RING CONSISTS OF:

- 2-HALVES . (HINGED IN MIDDLE)
- 2-CONNECTOR PLATES
- 4 - 5/16 X 1/2 BUTTON HEAD SCREWS

FINISH:  
POWDER COAT.  
COLOR: WHITE.

- RING TO BE INSTALLED ACCORDING TO CURRENT TRACK AND FIELD RULES AND SPECIFICATIONS.

NOTE: WE RECOMMEND INSTALLATION BE DONE BY A QUALIFIED CONTRACTOR, FAMILIAR WITH ALL CODES, LAWS, REGULATIONS, AND TRACK AND FIELD CONSTRUCTION.

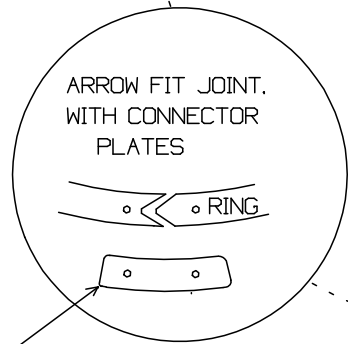
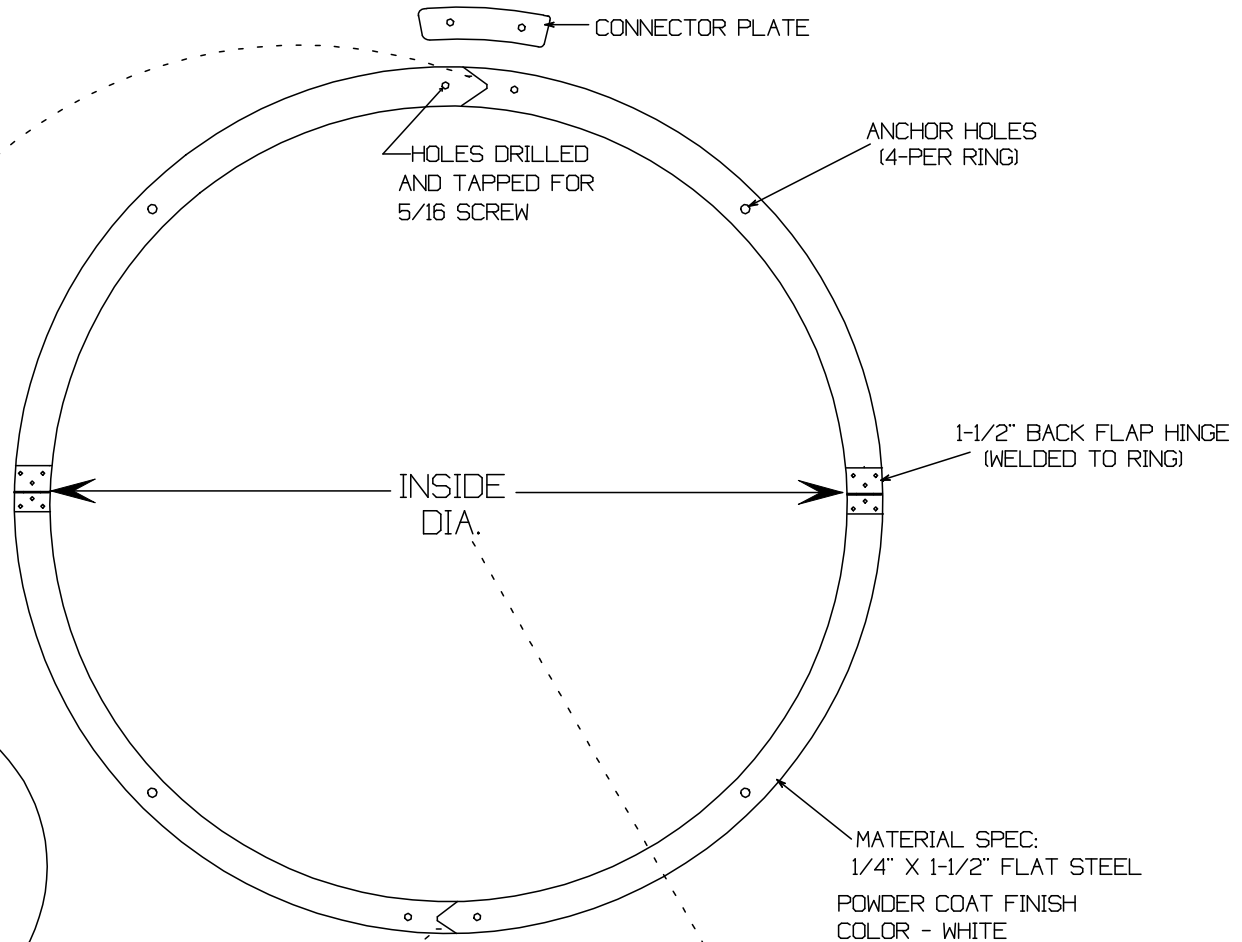

- CONNECTOR PLATE SPECS:
- 1/4" MILD STEEL
  - HOLES DRILLED FOR 5/16" SCREW
  - HARDWARE USED,  
5/16 X 1/2 BUTTON HEAD  
SOCKET CAP SCREW, 4-PER RING

CONNECTOR PLATES- 2-PER RING

MATERIAL SPEC:  
1/4" X 1-1/2" FLAT STEEL  
POWDER COAT FINISH  
COLOR - WHITE

INSIDE DIA. DIMENSIONS  
DIA. - 7'-0" FOR SHOT PUT RING  
DIA. - 8'-2-1/2" FOR DISCUS RING

www.stackhouseathletic.com

SCALE: NTS

**STACKHOUSE**  
athletic equipment

2-PC HINGED SHOT AND DISCUS RING - ALL STEEL

DATE: 12-08

SPECIFICATION DRAWING

DRAWN BY: S.L.

Phone: (503) 363-1840 Toll Free: (800) 285-3604  
Fax: (503) 363-0511 www.stackhouseathletic.com

SHEET 1 of 1

PRODUCT CODE: T2PCS / T2PCD

DWG: T2PCS/T2PCD SPEC-REV-08