

NOTE: WE RECOMMEND INSTALLATION BE DONE BY A QUALIFIED CONTRACTOR, FAMILIAR WITH ALL CODES, LAWS, REGULATIONS, AND TRACK AND FIELD CONSTRUCTION.

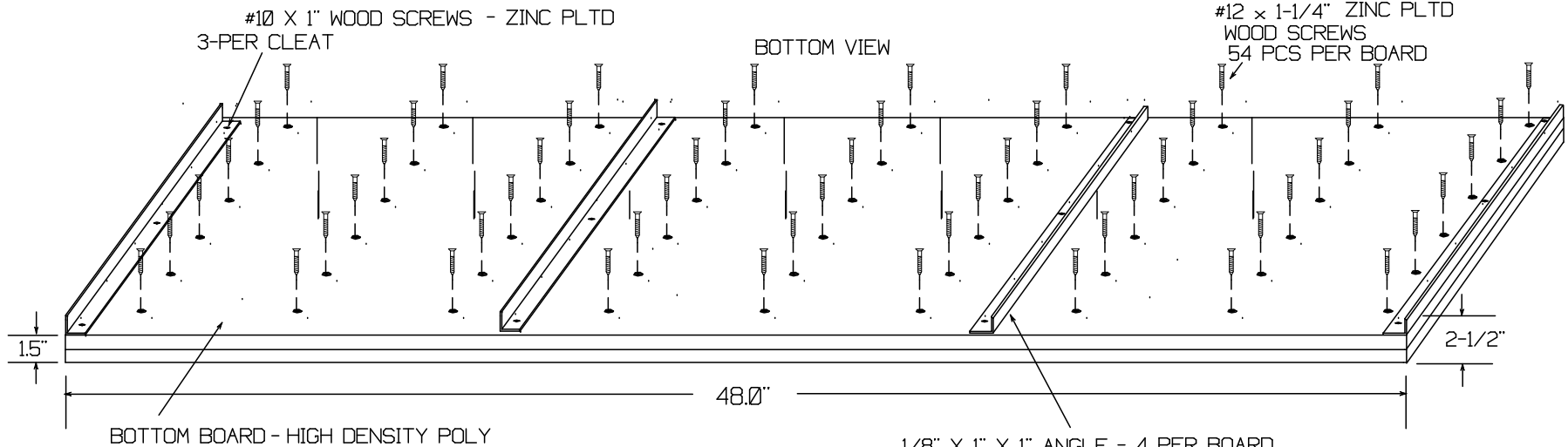

BOTTOM BOARD - HIGH DENSITY POLY

1/8" X 1" X 1" ANGLE - 4 PER BOARD
ATTACHED TO BOTTOM OF PLASTIC BOARDS

NOTE: BOARDS AND CLEATS
ATTACHED AT THE FACTORY

MATERIAL SPEC:
POLY BOARDS
2-PC 3/4" THICK
ATTACHED TOGETHER
WITH #12 X 1-1/4" WOOD SCREWS - ZINC PLTD
TO FORM A 1-1/2" THICK BOARD

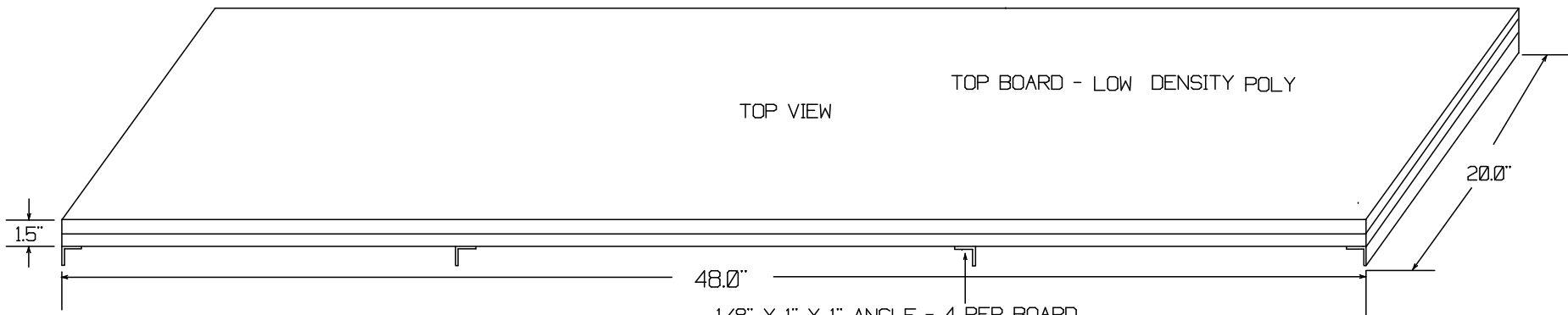

TOP BOARD - LOW DENSITY POLY

TOP VIEW

1/8" X 1" X 1" ANGLE - 4 PER BOARD
ATTACHED TO BOTTOM OF PLASTIC BOARDS
WITH #10 X 1" WOOD SCREWS - 3-PER CLEAT
CLEATS PAINTED FOR RUST PROTECTION

www.stackhouseathletic.com

SCALE: NTS

STACKHOUSE athletic equipment

POLY HIGH SCHOOL TAKE-OFF BOARD

DATE: 12-08

SPECIFICATION DRAWING

DRAWN BY: S.L.

Phone: (503) 363-1840 Toll Free: (800) 285-3604
Fax: (503) 363-0511 www.stackhouseathletic.com

SHEET 1 of 1

PRODUCT CODE: TPOLYTB

DWG: TPOLYTB SPEC-REV-08