

NOTE: WE RECOMMEND INSTALLATION BE DONE BY A QUALIFIED CONTRACTOR, FAMILIAR WITH ALL CODES, LAWS, REGULATIONS, AND TRACK AND FIELD CONSTRUCTION, AND THE INSTALLATION OF POLE VAULT SYSTEMS

MATERIALS NEEDED:

2" X 4" WOOD

2 @ 50" - FOR SIDES

1 @ 37" - FOR WIDE END

1 @ 27" FOR STOP BOARD END

4 @ 12" - STAKES (CUT POINTS ON ONE END)

APPROXIMATELY 400 lb. CONCRETE MIX, SAKRETE, READY-MIX ECT.

2" X 4" WOOD

1 @ 30" - HOLD DOWN

1 @ 39" - HOLD DOWN

16 @ - #16 FORMING NAILS

1- CONSTRUCT THE FORM;

REFER TO FORM DRAWINGS ON PAGE 2

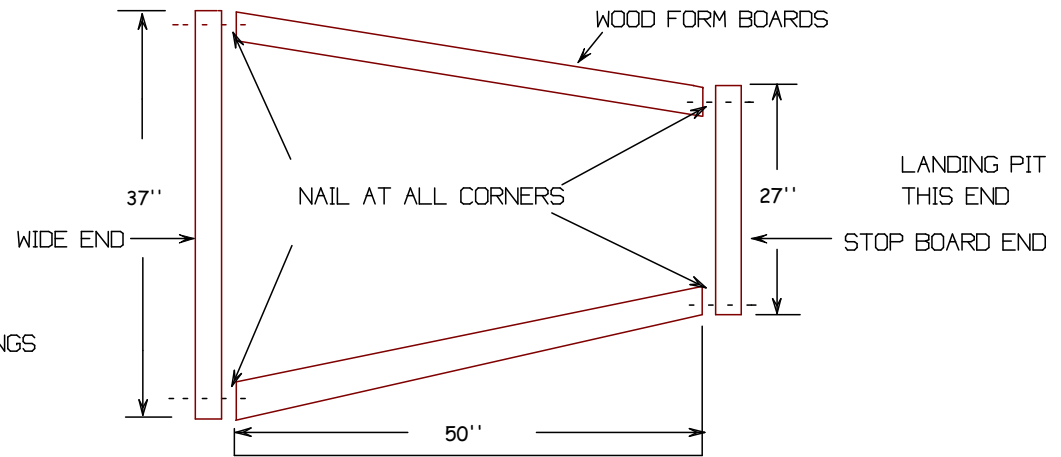

- 2- LOCATE THE DESIRED LOCATION OF THE VAULT BOX. DIG A HOLE (APPROXIMATE SHAPE OF THE VAULT BOX) TO ALLOW 2" - 3" OF CONCRETE AROUND THE PERIMETER OF VAULT BOX, AND GIVE ROOM TO INCLUDE THE FORMS. **CAUTION:** BE SURE TO PLACE THE DEEP END (STOPBOARD) CLOSEST TO THE PIT CENTERED WITH THE RUNWAY AND STANDARD PADS. DIG HOLE STRAIGHT DOWN AT THE STOPBOARD END, THIS WILL ALLOW FOR A GREATER CONCRETE CUSHION.
3. SET FORM LEVEL WITH THE RUNWAY AND SECURE IN PLACE BY DRIVING THE FOUR STAKES AT EACH CORNER OF FORM AND NAIL IN PLACE. **CAUTION:** CHECK TO MAKE SURE THE FORM IS LOCATED PROPERLY AND FLUSH WITH THE TAKE OFF AREA.
- 4- MIX CONCRETE TO RECOMENDED CONSISTENCY AND POUR ENOUGH INTO THE HOLE TO ALLOW PROPER SEATING FOR THE BOTTOM AND STOPBOARD END OF THE VAULT BOX. (APPROX. 2" TO 3") AT THE BOTTOM AND FRONT EDGE, AND (APPROX 2"- 4") AT THE STOP BOARD END.
- 5- PLACE BOX ON TOP OF CONCRETE AND SEAT FLUSH WITH THE TOP OF THE FORMS. MAKE SURE BOX IS FIRMLY SET IN CONCRETE AND THE STOPBOARD END BAKED WITH CONCRETE.
- 6- WHEN THE BOX IS PROPERLY SET, OR SEATED, NAIL 1- 2X4 X 30" ACROSS THE STOPBOARD END OF THE FORM, AND 1- 2X4 X 39" ACROSS THE FRONT EDGE OF THE FORM, TO PREVENT THE VAULT BOX FROM FLOATING UP AND OUT OF CONCRETE. **CAUTION:** MAKE ALL FINAL ADJUSTMENTS FOR PROPER ALIGNMENT AT THIS TIME.
- 7- FINISH FILLING AROUND THE SIDES OF THE VAULT BOX WITH CONCRETE. MAKE SURE THE CONCRETE IS WORKED COMPLETELY AROUND THE SIDES AND UNDER LIP OF VAULT BOX. TROWELING AND FINISH WORK CAN BE DONE AS TIME ALLOWS AS CONCRETE STARTS TO CURE AND DRY
NOTE: CONCRETE SHOULD BE ALLOWED TO CURE A MINIMUM OF 4 DAYS BEFORE USING.

www.stackhouseathletic.com

SCALE: NTS

STACKHOUSE

athletic equipment

Phone: (503) 363-1840 Toll Free: (800) 285-3604
Fax: (503) 363-0511 www.stackhouseathletic.com

STEEL VAULT BOX

DATE: 12-08

INSTALLATION INSTRUCTIONS - PAGE 1

DRAWN BY: S.L.

PAGE: 1 of 2

PRODUCT CODE: TSVB

DWG: TSVB INST PG1-REV-08

TOP VIEW OF COMPLETED
FORM, WITH ANCHORING STAKES

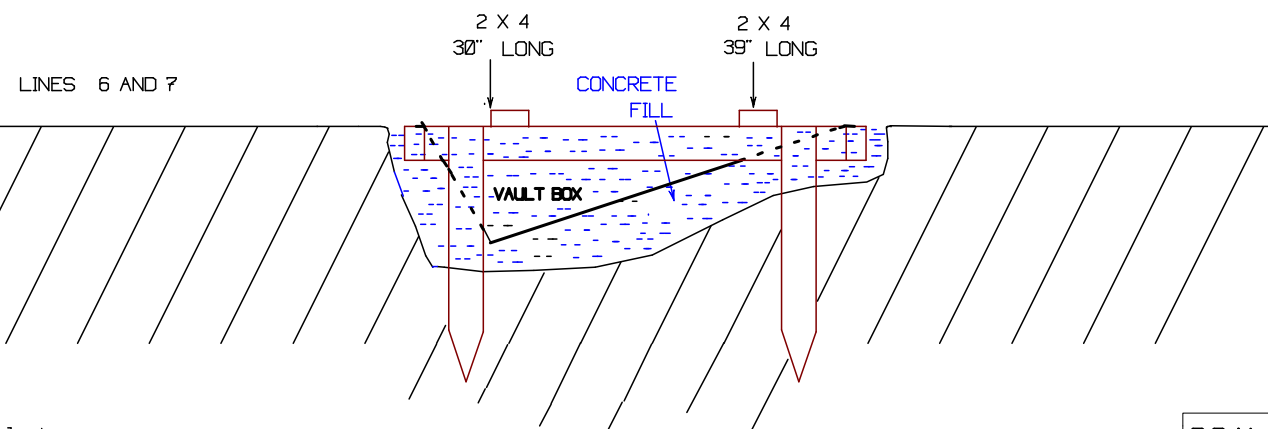
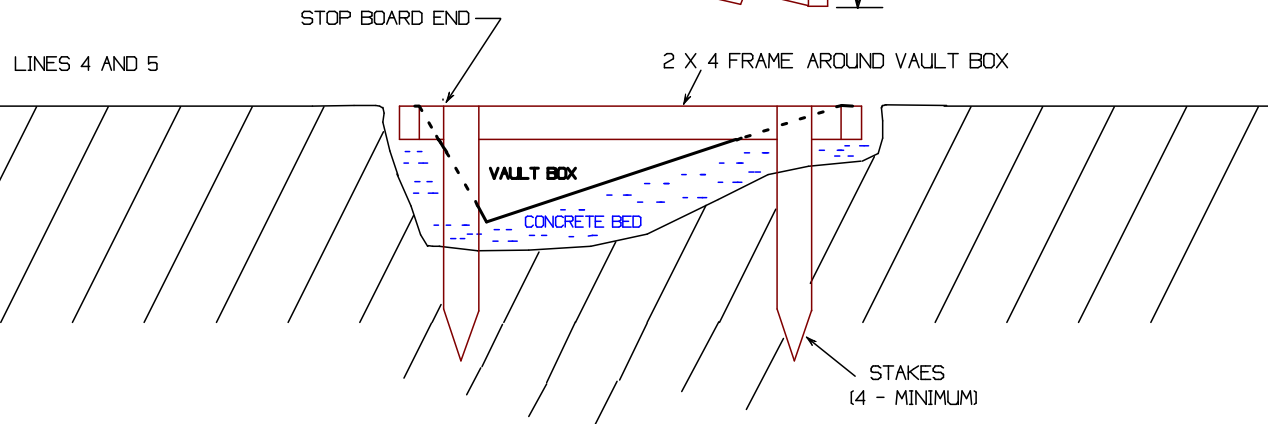
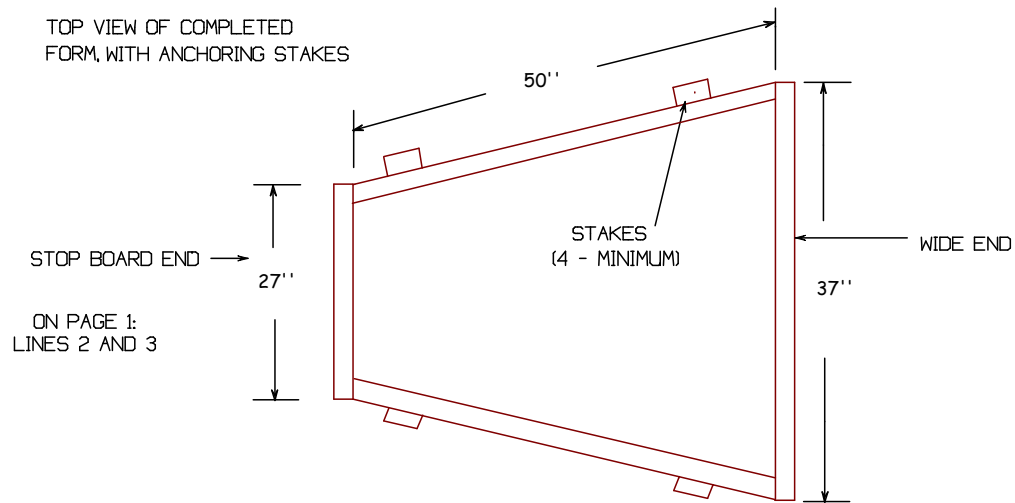

www.stackhouseathletic.com

STACKHOUSE

athletic equipment

Phone: (503) 363-1840 Toll Free: (800) 285-3604
Fax: (503) 363-0511 www.stackhouseathletic.com

STEEL VAULT BOX

INSTALLATION DRAWING - PAGE 2

PAGE: 2 of 2

PRODUCT CODE: TSVB

SCALE: NTS

DATE: 12-08

DRAWN BY: S.L.

DWG: TSVB INST PG2-REV-08