

INSTALLATION INSTRUCTIONS FOR FLOOR SLEEVE AND PLATES
ON CARPET OR TILE ON TOP, CONCRETE SLAB UNDERNEATH
FOR THE STACKHOUSE 3-1/2" VOLLEYBALL STANDARDS

NOTES: READ THESE INSTRUCTIONS IN COMPLETE BEFORE BEGINNING WORK
WE RECOMMEND INSTALLATION BE DONE BY A QUALIFIED CONTRACTOR
FAMILIAR WITH GYM FLOOR CONSTRUCTION AND ALL LOCAL CODES

- 1- LOCATE AND MARK THE EXACT POSITION OF THE FLOOR SLEEVES. (NORMALLY 3'-0" OFF THE COURT SIDELINE. FOR SINGLE COURT LAYOUTS, SLEEVES SHOULD BE 36'-0" CENTER TO CENTER. FOR SIDE BY SIDE COURTS WITH CENTER STANDARD, SLEEVES SHOULD ALSO BE 36'-0" ON CENTER.
- 2- USING THE FLOOR PLATE AS A GUIDE, TRACE OUTLINE OF THE TOP PLATE ON THE FLOOR. (THIS SHOULD BE 6-13/16" DIAMETER) ACCURATELY CUT AWAY TOP SYNTHETIC MATERIAL, CHISEL AND REMOVE ENOUGH MATERIAL TO ALLOW PLATE TO FIT FLUSH WITH THE FINISH FLOOR.
- 3- DRILL A HOLE (ON CENTER) IN THE CONCRETE SUBFLOOR 5-1/2" TO 6" IN DIAMETER. USE A CORE BIT OR ROTO HAMMER. IF USING A ROTO HAMER, DRILL A SERIES OF SMALLER HOLES AROUND THE CIRCUMFERENCE OF THE 5" DIAM CENTER , AND KNOCK OUT. DRILL HOLE DOWN TO A DEPTH OF APPROX 14"
- 4- CLEAN OUT MATERIAL FROM HOLE AND DOUBLE CHECK FOR FIT. ALSO (IMPORTANT) CHECK SLEEVE AND COVER UNIT FOR DAMAGE TO SPACERS AND SCREWS, AND THAT THE UNIT IS STRAIGHT, OR POST WILL NOT BE LEVEL WHEN SET.
- 5- PLUG OPENING IN SLEEVE OR FILL WITH PAPER TO KEEP GROUT FROM FILLING SLEEVE. USE A NON-SHRINK CONCRETE GROUT WITH A FINAL CURE STRENGTH OF OVER 6,500 POUNDS. MANUFACTURERS: EMBECO, HYDROCID, SUPER ROCK, AND MASTERBUILDERS, MASTERFLOW #713.
- 6- POUR GROUT INTO HOLE, APPROX 1/2 FULL. PUSH SLEEVE DOWN INTO GROUT UNTILL PLATE SEATS FLUSH WITH THE FLOOR. FILL REMAINING VOIDS AROUND OUTSIDE OF SLEEVE WITH LID REMOVED. LEAVE THE TWO UNITS MOUNTED TOGETHER PERMANENTLY.
- 7- WE RECOMMEND THE COVERS BE LEFT OPEN FOR 24 HOURS TO ALLOW MOISTURE TO ESCAPE. KEEP ALL ACTIVITIES OFF OF THE IMMEDIATE AREA SURROUNDING THE FLOORPLATE FOR 48 HOURS. ALLOW 10 DAYS CURING TIME BEFORE USING EQUIPMENT.

www.stackhouseathletic.com

SCALE:



3-1/2" I.D. FLOOR SLEEVE AND PLATE FOR VOLLEYBALL STANDARDS

DATE: 12-08

INSTALLATION ON CARPET OR TILE FLOORS - PG1

DRAWN BY: S.L.

Phone: (503) 363-1840 Toll Free: (800) 285-3604
Fax: (503) 363-0511 www.stackhouseathletic.com

PAGE: 1 of 2

PRODUCT CODE: VTFC3.5S

DWG: VTFC3.5S INSTALL CARPET PG1

INSTALLATION DRAWING:

**FLOOR SLEEVES AND PLATES FOR THE STACKHOUSE
3-1/2" VOLLEYBALL STANDARDS ON CARPET,
OR TILE ON TOP SURFACE, CONCRETE SUB FLOOR.**

NOTE: AFTER GROUT IS SET, REMOVE THE FOUR SCREWS AND SPACERS TO ALLOW FOR MOVEMENT IN FLOOR

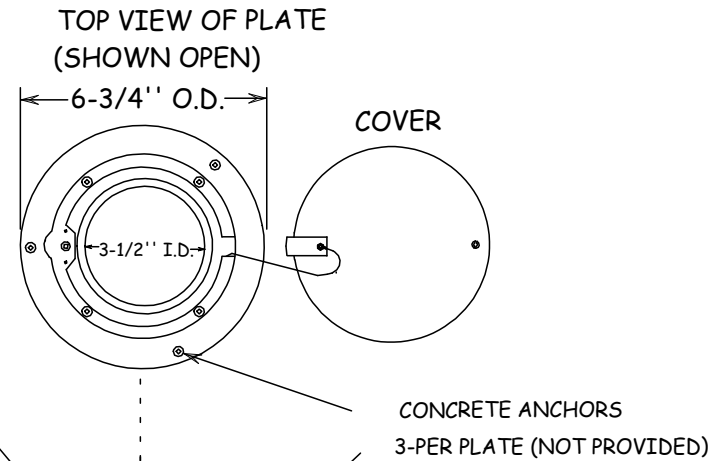

CARPET OR TILE SURFACE

CONCRETE SLAB

GROUT

GRADE

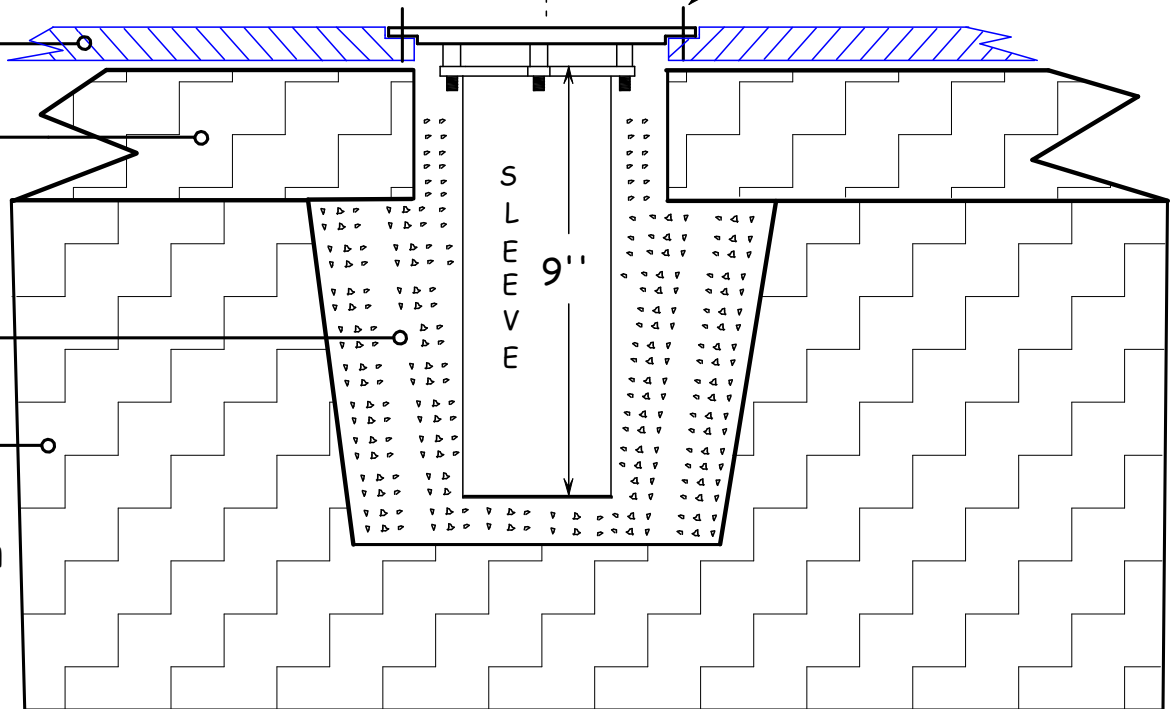

NOTE: FOR FLOOR AND SUB FLOOR CONSTRUCTION OTHER THAN SHOWN, CONTACT MANUFACTURER.

www.stackhouseathletic.com

SCALE: NTS



3-1/2" I.D. FLOOR SLEEVE AND PLATE FOR VOLLEYBALL STANDARDS

DATE: 12-08

INSTALLATION ON CARPET OR TILE FLOORS - PG2

DRAWN BY: S.L.

Phone: (503) 363-1840 Toll Free: (800) 285-3604
Fax: (503) 363-0511 www.stackhouseathletic.com

PAGE: 2 of 2

PRODUCT CODE: VTFC3.5S

DWG: VTFC3.5S INSTALL CARPET PG2